



CAP 18WLL

Pass Thru Air Lock Cleanroom Entry System

S
N
O
I
T
U
T
O
S

The CAP18WLL Wall Mounted Lead Lined Pass Thru airlock cleanroom entry system is designed for those cleanrooms where radiation protection is required for personnel. The CAP18WLL is designed with a 1/4 inch thick QQ-L-201F Certified Grade B lead sheet lining, and lead glass viewing windows for radiation shielding for those specialized cleanroom needs.

As with all CAP Pass Thrus, the CAP18WLL has an innovative double wall design, stainless steel integrity, and the solid construction of formed and stitch-welded stainless steel.

Doors are secured with heavy duty over center stainless steel Compression Lever Latches that tightly seal. Mechanical interlocks prevent air depressurization from both doors from being opened at the same time. The doors feature clear lead glass windows that provide radiation protection of 3mm lead equivalency and 200kV X-Ray peak voltage rating.

The superior engineering of the CAP18WLL design and stainless steel construction means maximum value, flexibility and ease of cleaning and maintenance. The CAP18WLL Pass Through maximizes radiation protection for personnel, and its elegant look upgrades the appearance of any cleanroom.



For more information or to download or fax this product from the web, go to:
www.cleanairproducts.com/18W

Standard features

- Formed and stitch-welded Type 304 #4 finish Stainless steel construction
- Stainless steel encapsulates 1/4 inch thick Q-L-201F Certified Grade B lead sheet (door and body)
- Clear lead glass windows with 3mm lead equivalency and 200kV X-Ray peak voltage rating
- Stainless steel flush-mounted hinge
- Stainless steel door frame
- Mechanical Interlock
- Type 316 Stainless Steel Lever compression door latches



Options

- Electropolished Type 304 #4 Stainless steel
- Type 316L #2b finish Stainless steel
- Electropolished Type 316 Stainless steel
- Powder Coated Painted Cold Rolled Steel (Clean Air Products standard white)
- Powder Coated Painted Cold Rolled steel (Customer-specified color)
- Stainless steel Support Gussets
- Stainless steel Support Legs
- Specialized Sizes

Specifications subject to change. Please contact factory for details.



Solutions Built to Your Specifications.

8605 Wyoming Ave. N. • Minneapolis MN 55445

tel: 763.425.9122 800.423.9728 fax: 763.425.2004

e-mail: sales@cleanairproducts.com www.cleanairproducts.com

Series 18WLL Pass Thru Air Lock Cleanroom Entry System

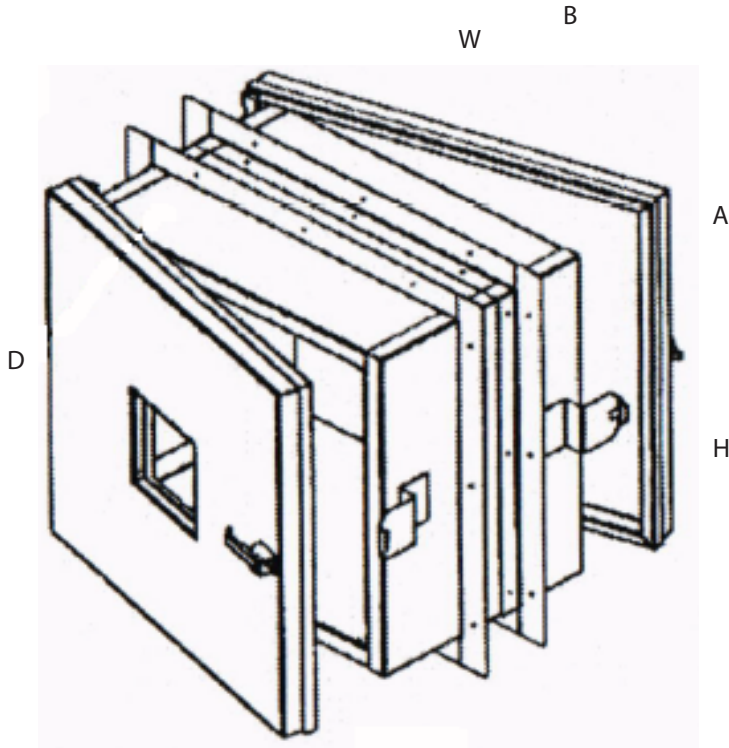

Sizes and Weight

The CAP 18WLL is available in many standard sizes. Unit sizes are based on inside dimensions.

Weight is approximately 300 lbs. Contact us if you have any questions.

Guarantee

A written 1 year warranty is furnished with each air lock.

Wall Mount — Dimensions (inches)

CAP18WLL

MODEL #	Inside Dimensions			Outside Dimensions	
	W	H	D	A	B
CAP18WLL-SST-18Wx24Hx18D	18	18	18	21.375	21.625
CAP18WLL-SST-18Wx24Hx18D	18	24	18	27.375	20.625
CAP18WLL-SST-24Wx24Hx24D	24	24	24	27.375	27.625
CAP18WLL-SST-30Wx30Hx30D	30	30	30	33.375	33.625
CAP18WLL-SST-36Wx36Hx36D	36	36	36	39.375	39.625
CAP18WLL-SST-46Wx46Hx30D	46	46	30	49.375	49.625
CAP18WLL-SST-46Wx46Hx46D	46	46	46	49.375	49.625

Specifications subject to change. Please contact factory for details.