



CAP 18WVS

Wall Mount Manual Vertical Sliding Doors Pass Thru

S
N
O
I
T
U
T
O
S

The CAP18WVS Wall Mounted Manual Vertical Sliding Doors Pass Thru airlock cleanroom entry system enables transfer of parts and equipment in and out of a cleanroom with a sliding vertical door access in a confined space or where a standard swing door is not suitable (the sliding door causes less air turbulence within the cleanroom than a swing door.)

The CAP18WVS is rigid and self-supporting double wall stainless steel construction that can be mounted in a variety of configurations. Counter-weighted doors are easy to open with Anodized aluminum door pulls. Doors can be secured with optional mechanical interlocks that avoid air depressurization of the cleanroom by preventing both doors from being opened at the same time.

The superior engineering of the CAP18WVS design provides maximum flexibility in another important way—mounting configuration. It can be mounted flush against existing walls, or center-mounted with optional stainless steel mounting frames. This combination of high quality, heavy-duty construction and innovative design makes the CAP18WVS provides a space-saving solution for cleanroom operations in confined spaces, and provides an elegant look to any cleanroom.



For more information or to download or fax this product from the web, go to:
www.cleanairproducts.com/18W

Standard features

- Fitted and stitch-welded Type 304 #4 finish Stainless Steel construction
- Counter-weighted, manually-operated, vertical sliding doors
- Clear acrylic viewing windows
- Anodized Aluminum door pulls
- Maximum interior width: 92 inches

Options

- Electropolished Type 304 #4 finish Stainless Steel
- Type 316L #2b finish Stainless Steel
- Electropolished Type 316L #2 finish Stainless steel
- Powder Coated Painted Cold Rolled Steel (Clean Air Products standard white)
- Powder Coated Painted Cold Rolled Steel (Customer-specified color)
- Push Rod Interlock
- Door window material options: Clear Tempered Safety Glass, Clear Wire Safety glass, Clear Laminated Safety Glass, amber Tempered Safety Glass; Clear PVC and ESD PVC; Clear Polycarbonate, Yellow, Amber, Tinted UV Light Filtering Acrylic, and Stainless Steel (no window)
- Stainless Steel Support Gussets
- Stainless Steel Support Legs
- Stainless Steel Adjustable Shelf
- Perforated Stainless steel Adjustable Shelf
- Solid Stainless Steel Adjustable Shelf
- Perforated Stainless Steel Adjustable Shelf
- Solid Stainless Steel Non-adjustable Set-In Shelf
- Perforated Stainless Steel Non-adjustable Set-In Shelf
- Stainless Steel Catch Tray
- Duplex Receptacle with Stainless Steel Cover
- UV light (with or without timed shut off)
- Ventilation Couplings
- Door Position Indicator Lights



Specifications subject to change. Please contact factory for details.

CAP18 WVS Pass Thru Air Lock Cleanroom Entry System

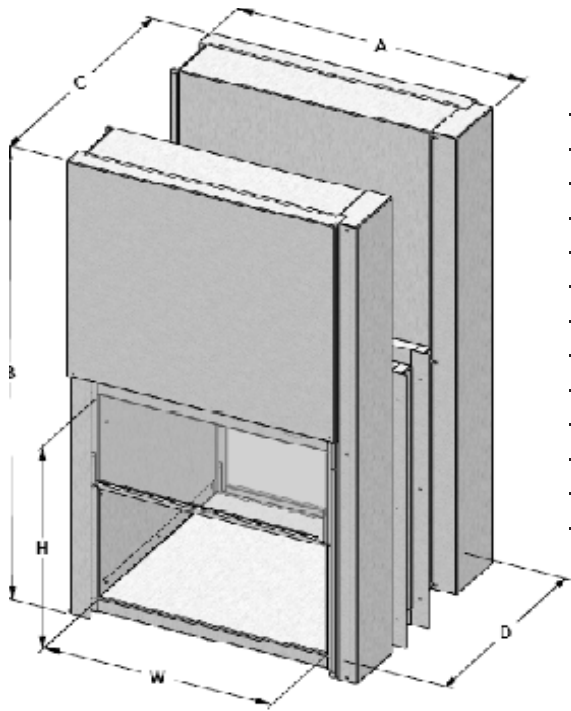

CAP 18WVS Pass Thrus --Dimensions (inches)

MODEL #	Inside Dimensions			Outside Dimensions		
	W	H	D	A	B	C
CAP18WVS-SST-12Wx12Hx24D	12	12	24	20	31	30
CAP18WVS-FFR-SST-18Wx18Hx24D	18	18	24	26	43	30
CAP18WVS-FFR-SST-24Wx24Hx24D	24	24	24	32	55	30
CAP18WVS-FFR-SST-30Wx30Hx30D	30	30	30	38	67	36
CAP18WVS-FFR-SST-36Wx24Hx36D	36	24	36	44	55	30
CAP18WVS-FFR-SST-36Wx36Hx36D	36	36	36	50	55	42
CAP18WVS-FFR-SST-42Wx24Hx36D	42	24	36	50	79	48
CAP18WVS-FFR-SST-42Wx36Hx42D	42	36	42	50	91	48
CAP18WVS-FFR-SST-42Wx42Hx42D	42	42	42	50	91	48
CAP18WVS-FFR-SST-48Wx24Hx36D	48	24	36	56	55	42
CAP18WVS-FFR-SST-48Wx36Hx36D	48	36	36	56	79	42

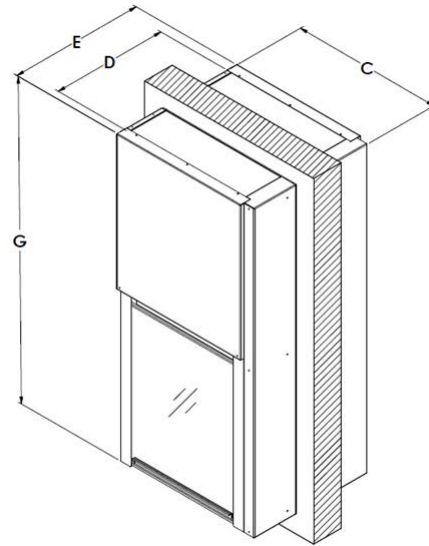
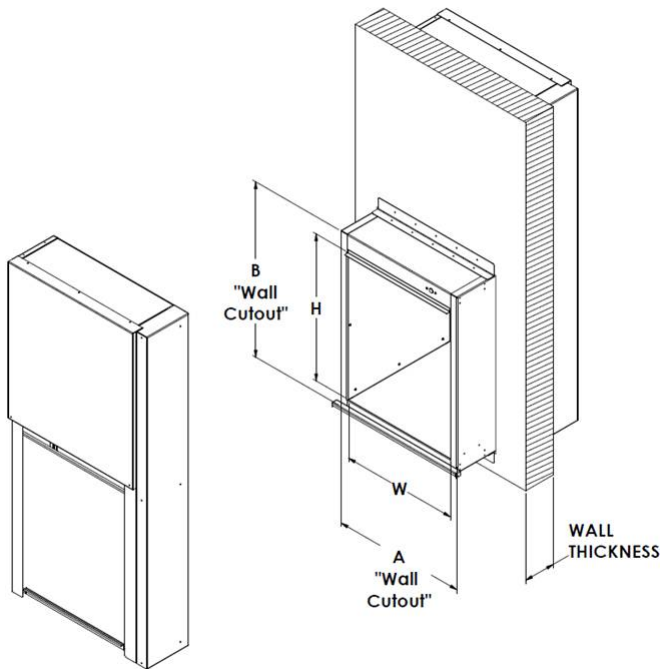

Sizes and Weight

The CAP 18WVS is available in many standard sizes. Unit sizes are based on inside dimensions. Weight depends on size and options package. Contact us if you have any questions.

Guarantee

A written 1 year warranty is furnished with each air lock.

Specifications subject to change. Please contact factory for details.



Solutions Built to Your Specifications.

8605 Wyoming Ave. N. • Minneapolis MN 55445

tel: 763.425.9122 800.423.9728 fax: 763.425.2004

e-mail: sales@cleanairproducts.com www.cleanairproducts.com