

NOTES: UNLESS OTHERWISE SPECIFIED
 1. DIMENSIONS ARE IN INCHES (mm).

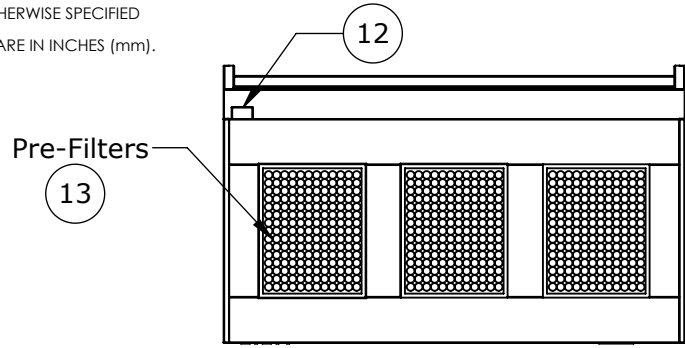

Prefilters can be relocated to the front or back of unit. Leave minimum of 4 inches of clearance from filter face

Top Cabinet ships separate from the lower frame

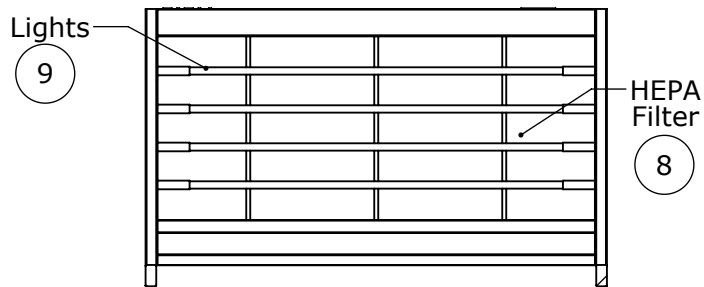
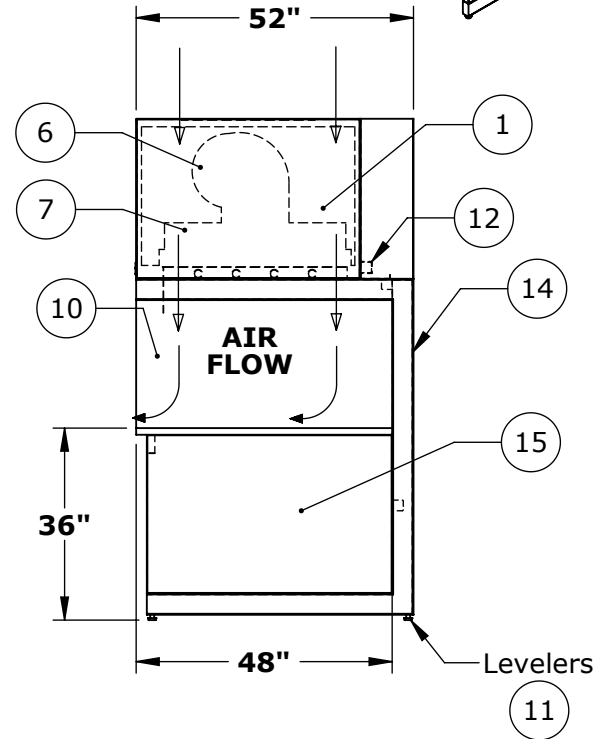
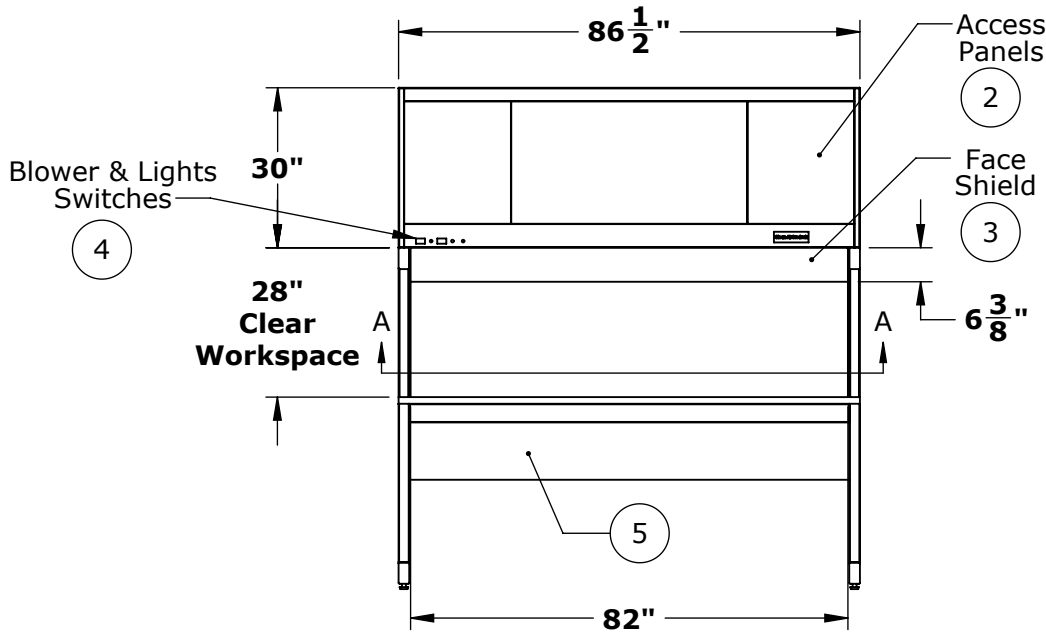
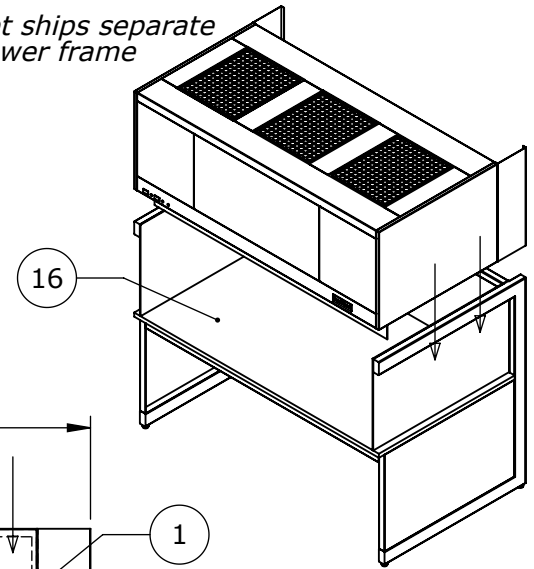

SECTION A-A



© COPYRIGHT 2010 CLEAN AIR PRODUCTS	Clean Air PRODUCTS 8605 WYOMING AVENUE NORTH • MINNEAPOLIS, MN 55445 800-423-9728 • ph: 763-425-9122 • fax: 763-425-2004 www.cleanairproducts.com
	DESCRIPTION. Vertical Flow Clean Bench CAP412-7T48-36H-WO
	QUOTE NO.
	DO NOT SCALE
DATE DRAWN 04/16/2012	QUOTE FORM 035204
REV 1	SHEET 1 of 2

NOTES: UNLESS OTHERWISE SPECIFIED

1. DIMENSIONS ARE IN INCHES (mm).

Notes:

1. **Top Cabinet, 16ga CRS with White Powder Coat Finish**
2. **Blower and Filter Access Panels, Front and Rear
(Field Personnel Can Relocate These In Order To Mount Prefilters In The Front)**
3. **Front Face Shield, 80mil Clear Flexible Vinyl**
4. **Control Panel, Blower and Light Switch, Circuit Breakers**
5. **Back Panel, 18ga. Vinyl Coated Steel**
6. **Double Blowers, 1/2HP + 3/4HP, 120V, 60Hz**
7. **Supply Plenum, metal over top of HEPA, Flex duct to blower**
8. **HEPA, 99.99% on 0.3 micron particles, Aluminum anodized frame**
9. **Lights, Fluorescent Lamps, F72T12 (4x)**
10. **End Shields, Clear Polycarbonate**
11. **Leg Leveling Glides, Adjustable +/- 1/2"**
12. **Electrical Junction Box, (120V, 60Hz, 18.76 FLA)**
13. **Prefilters, 20x25x1 Glass Fiber (3x) Note: Can Be Field Relocated in the Field**
14. **Lower Support Frame, "C" Style, HRS with White Powder Coat**
15. **Side Work Surface Supports, Vinyl Coated Steel**
16. **White Formica Work Surface**

Optional:

17. **Power Cord - 14 ft Long**
18. **304 #4 Finish Stainless Steel Back Panel**
19. **304 #4 Finish Stainless Steel Side Panel**
20. **304 #4 Finish Stainless Steel "C"-Frame**
21. **304 #4 Finish Stainless Steel Top Cabinet**
22. **Low Profile - 20" Tall Top Cabinet (Normally 30" Tall)**
23. **ULPA Filters - ISO Class 4, Fed Std 209E 10**

Shipping Note:

1. **Top Cabinet Shipped
Separate from "C"-Frame**

© COPYRIGHT 2010 CLEAN AIR PRODUCTS	Clean Air PRODUCTS 8605 WYOMING AVENUE NORTH • MINNEAPOLIS, MN 55445 800-423-9728 • ph: 763-425-9122 • fax: 763-425-2004 www.cleanairproducts.com			
	DESCRIPTION. Vertical Flow Clean Bench CAP412-7T48-36H-WO			
	QUOTE NO.			
	DO NOT SCALE			
	DATE DRAWN 04/16/2012	QUOTE FORM 035204	REV 1	SHEET 2 of 2