

NOTES: UNLESS OTHERWISE SPECIFIED  
 1. DIMENSIONS ARE IN INCHES (mm).

*Top Cabinet ships separately  
 from the lower frame*

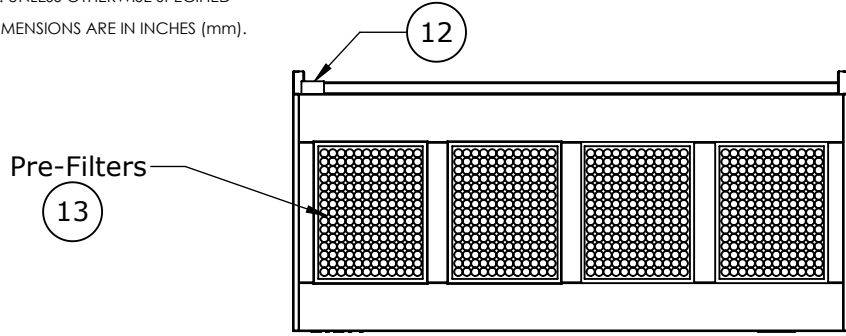

*Prefilters can be relocated  
 to the front or back of unit.  
 Leave minimum of 4 inches of  
 clearance from filter face*

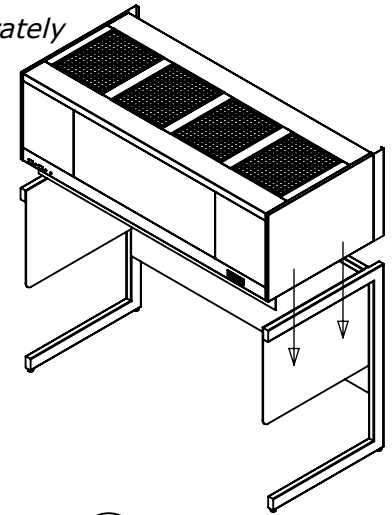
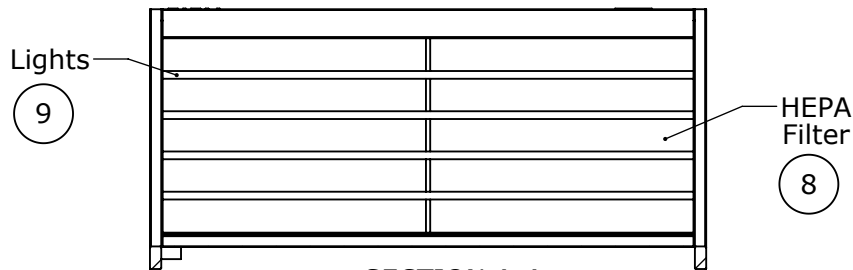
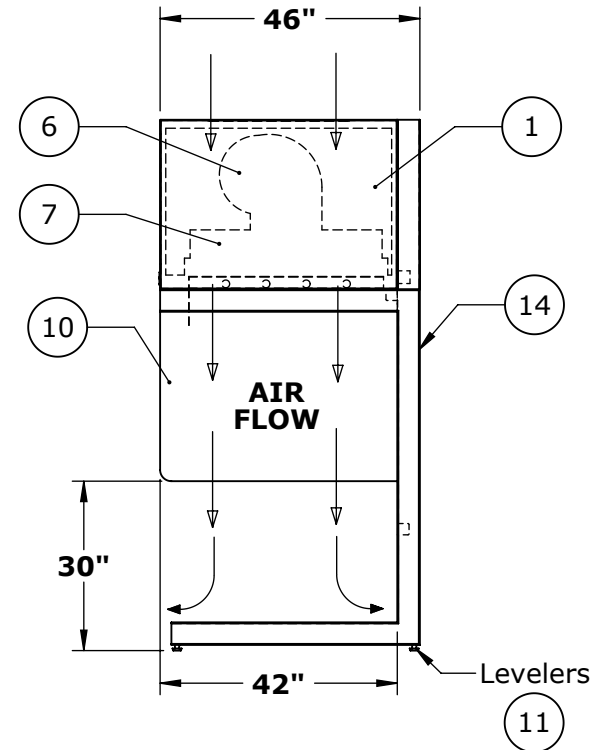
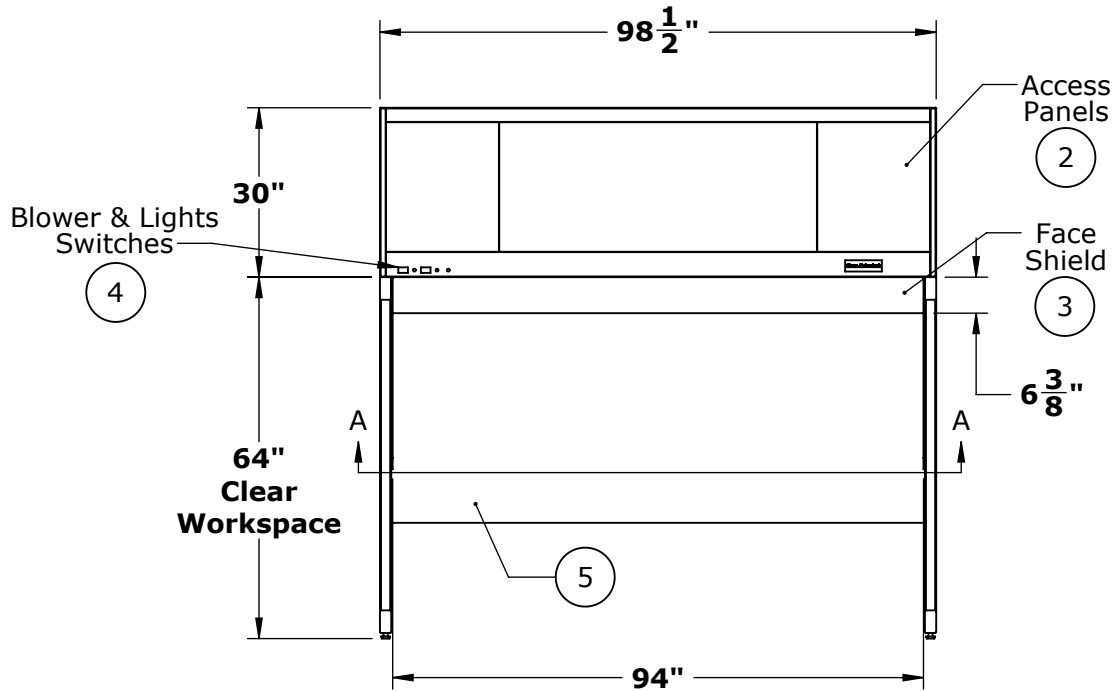

SECTION A-A

© COPYRIGHT 2010 CLEAN AIR PRODUCTS	<b>Clean Air PRODUCTS</b> 8605 WYOMING AVENUE NORTH • MINNEAPOLIS, MN 55445 800-423-9728 • ph: 763-425-9122 • fax: 763-425-2004 www.cleanairproducts.com
	DESCRIPTION. <b>Vertical Flow Clean Bench          CAP412-8T42-30H-OB</b>
	QUOTE NO.
	<b>DO NOT SCALE</b>
DATE DRAWN 04/12/2012	QUOTE FORM 030905
REV 1	SHEET 1 of 2

NOTES: UNLESS OTHERWISE SPECIFIED

1. DIMENSIONS ARE IN INCHES (mm).

**Notes:**

1. **Top Cabinet, 16ga CRS with White Powder Coat Finish**
2. **Blower and Filter Access Panels, Front and Rear  
(Field Personnel Can Relocate These In Order To Mount Prefilters In The Front)**
3. **Front Face Shield, 80mil Clear Flexible Vinyl**
4. **Control Panel, Blower and Light Switch, Circuit Breakers**
5. **Back Panel, 18ga. Vinyl Coated Steel**
6. **Double Blowers, 1/2HP, 120V, 60Hz**
7. **Supply Plenum, metal over top of HEPA, Flex duct to blower**
8. **HEPA, 99.99% on 0.3 micron particles, Aluminum anodized frame**
9. **Lights, Fluorescent Lamps, F96T12 (4x)**
10. **End Shields, Clear Polycarbonate**
11. **Leg Leveling Glides, Adjustable +/- 1/2"**
12. **Electrical Junction Box, (120V, 60Hz, 15.1 FLA)**
13. **Prefilters, 20x25x1 Glass Fiber (4x) Note: Can Be Field Relocated in the Field**
14. **Lower Support Frame, "C" Style, HRS with White Powder Coat**

**Optional:**

1. **Power Cord - 14 ft Long**
2. **304 #4 Finish Stainless Steel Back Panel**
3. **304 #4 Finish Stainless Steel Side Panel**
4. **304 #4 Finish Stainless Steel "C"-Frame**
5. **304 #4 Finish Stainless Steel Top Cabinet**
6. **20" Tall Top Cabinet (Normally 30" Tall)**
7. **ULPA Filters - ISO Class 4, Fed Std 209E 10**

**Shipping Note:**

1. **Top Cabinet Shipped  
Separate from "C"-Frame**

© COPYRIGHT 2010 CLEAN AIR PRODUCTS	<b>Clean Air PRODUCTS</b> 8605 WYOMING AVENUE NORTH • MINNEAPOLIS, MN 55445 800-423-9728 • ph: 763-425-9122 • fax:763-425-2004 www.cleanairproducts.com						
	DESCRIPTION. <b>Vertical Flow Clean Bench CAP412-8T42-30H-OB</b>						
	QUOTE NO.						
	<b>DO NOT SCALE</b>						
DATE DRAWN	04/12/2012	QUOTE FORM	030905	REV	1	SHEET	2 of 2