

NOTES: UNLESS OTHERWISE SPECIFIED

1. DIMENSIONS ARE IN INCHES (mm).

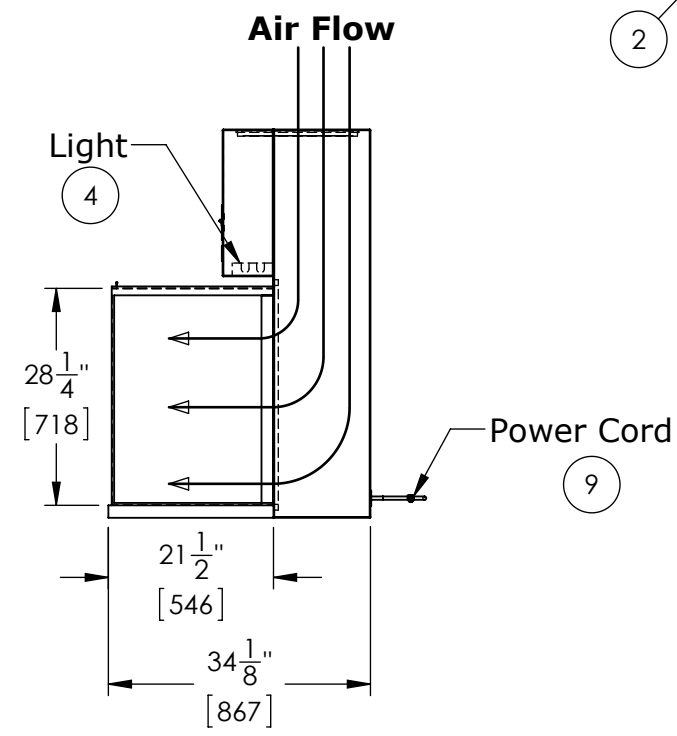
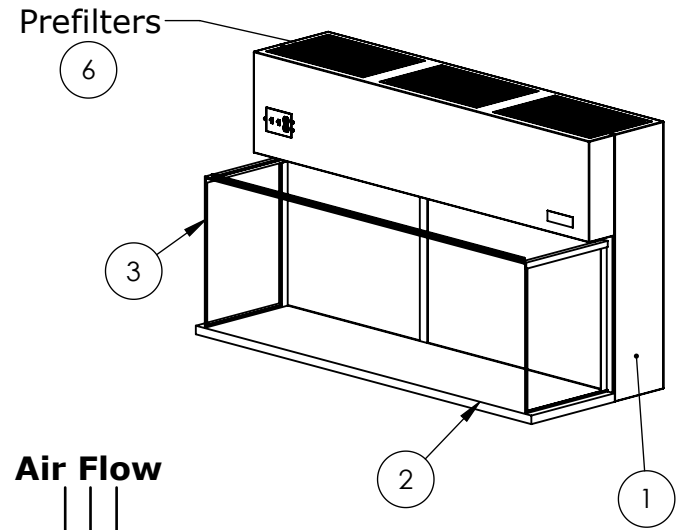
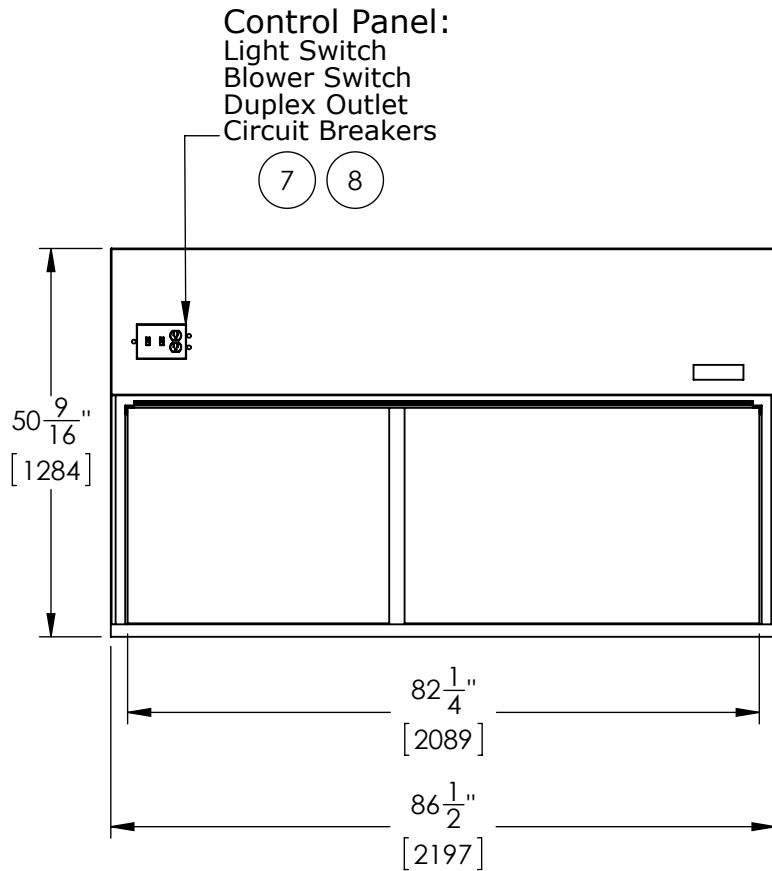

© COPYRIGHT 2010 CLEAN AIR PRODUCTS	Clean Air PRODUCTS		8605 WYOMING AVENUE NORTH • MINNEAPOLIS, MN 55445 800-423-9728 • ph: 763-425-9122 • fax: 763-425-2004 www.cleanairproducts.com		
	DESCRIPTION. Horizontal Flow Clean Bench CAP201-730-2108D				
	QUOTE NO.				
	DO NOT SCALE	DATE DRAWN 01/10/2013	QUOTE FORM 038731	REV 1	SHEET 1 of 2

NOTES: UNLESS OTHERWISE SPECIFIED

1. DIMENSIONS ARE IN INCHES (mm).

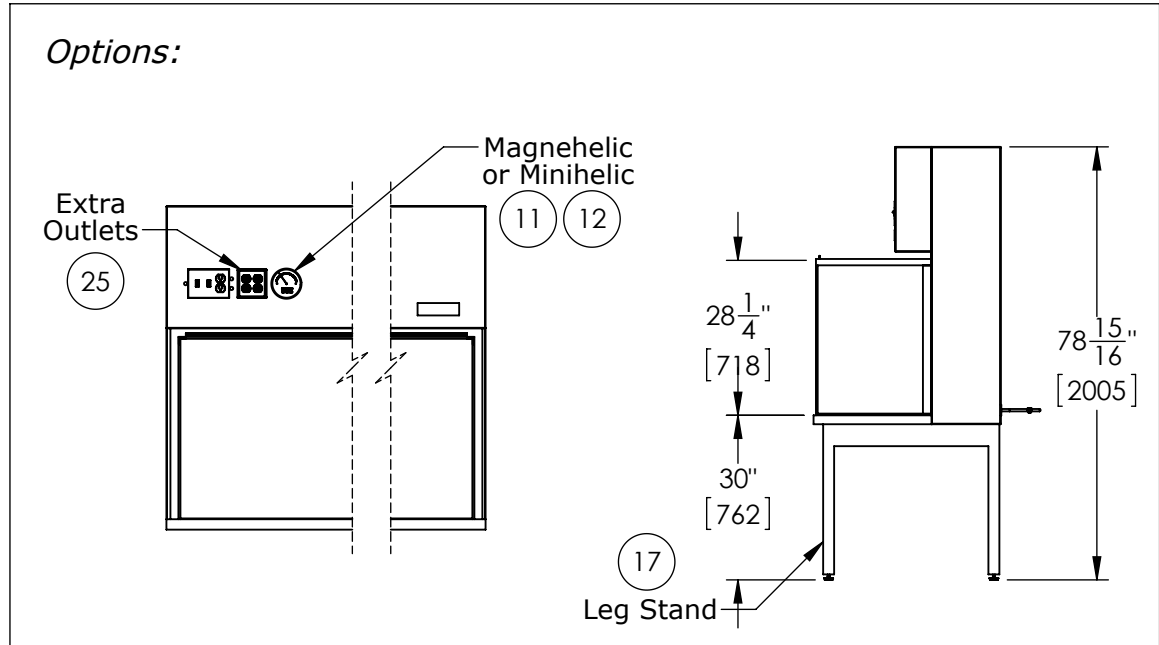
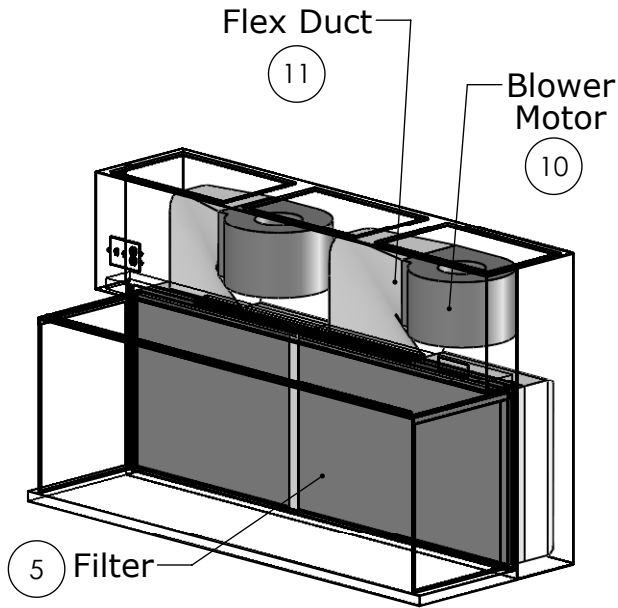

Standard Features:

1. Heavy Gauge White Vinyl Clad Steel Construction
2. White Plastic Laminate Table Top Material
3. Clear Polycarbonate Hood Panels
4. Fluorescent Light - T8 Lamps
5. Front Removable HEPA- 99.99% on 0.3 Micron Filter (Expanded Steel, Epoxy Painted, Screen On Final Filter Face)
6. Fiberglass Pre-filter On Top Of Cabinet
7. Electrical Service: Convenience Receptacle (4 Amps Available), 120V, 1-Phase, 3 Wire, With Power Cord, 15.29 A FLA
8. Blower & Light Switch
9. Power Cord (5-20P)
10. Blower Motor
11. Flex Duct

Options:

12. Magnehelic Gage
13. Minihelic Gage
14. Stainless Steel Work Surface
15. Stainless Steel Cabinet
16. Conductive Plastic Laminate Table Top
17. Leg Stand, Increases Work Surface To 30" From Floor
18. Ion Bar System
19. Grill on HEPA (Removable)
20. Anti-Static PVC Hood Panels
21. Safety Glass Hood Panels
22. Safety Glass Top & Stainless Hood Panels
23. Deeper Work Surface (27" & 33")
24. ULPA - 99.999% on 0.12 Micron Filter
25. Extra Service Receptacle-Separate 15 A Power Cord Remove Convenience Receptacle To Allow For A 5-20 Plug, This Would Achieve 11.29 A FLA
- 26.

© COPYRIGHT 2010 CLEAN AIR PRODUCTS	Clean Air PRODUCTS	8605 WYOMING AVENUE NORTH • MINNEAPOLIS, MN 55445 800-423-9728 • ph: 763-425-9122 • fax:763-425-2004 www.cleanairproducts.com	
	DESCRIPTION.	Horizontal Flow Clean Bench CAP201-730-2108D	
	QUOTE NO.		
	DO NOT SCALE	DATE DRAWN 01/10/2013	QUOTE FORM 038731
		REV 1	SHEET 2 of 2