

### General Description

#### Cabinet

Heavy gauge white Vinclad steel exterior finish. The vinyl is 8 to 10 mils in thickness. It is resistant to abrasion, corrosion, stains, and attacks by chemicals. Vinclad will not support combustion; it is resistant to scratch or scuff, will not chip, craze or crack. Vinclad is peel proof and has moderate acoustical control.

The table work surface is fabricated of white plastic laminate over particle-board. Providing a durable, cleanable and attractive surface.

Two white fluorescent lamps, with energy efficient ballast, are provided to illuminate work area. An on/off switch is provided for lamp control.

The work area hood assembly is fabricated of clear acrylic. The hood provides a controlled work area and assists in directional air flow.

#### Filters

#### Final

A negative pressure Flex Duct filter system prevents contaminants from entering work area as commonly seen in positive pressure filter systems.

The HEPA final filter is 99.99% effective on particles 0.3 micron and larger. D.O.P. Smoke tested and leak probed. Standard final filters have fire retardant frames and aluminum separators.

The final filter is protected by a flattened expanded aluminum grill.

### Filter Sizes

201-24 HEPA Filters			Prefilters	
224	(1)	24X24X6	(1)	16x20
324	(1)	24x36x6	(1)	16x25
424	(1)	24x48x6	(2)	16x20
524	(2)	24x30x6	(2)	16x20
624	(2)	24x36x6	(2)	16x25
824	(2)	24x48x6	(3)	16x25
201-30 HEPA Filters			Prefilters	
230	(1)	24x30x6	(1)	16x20
330	(1)	30x48x6	(1)	16x20
430	(1)	30x30x6	(1)	16x20
530	(2)	30x30x6	(2)	16x20
630	(2)	30x36x6	(2)	16x25
830	(2)	30x48x6	(3)	16x25
201-36 HEPA Filters			Prefilters	
336	(1)	30x36x6	(1)	16x20
436	(2)	24x36x6	(1)	16x25
536	(2)	36x30x6	(2)	16x20
636	(2)	36x36x6	(2)	16x25
836	(4)	36x24x6	(3)	16x25
201-48 HEPA Filters			Prefilters	
448	(2)	48x24x6	(1)	16x25
548	(2)	48x30x6	(2)	16x20
648	(4)	24x36x6	(2)	16x25
848	(4)	48x24x6	(3)	16x25

## Series 201

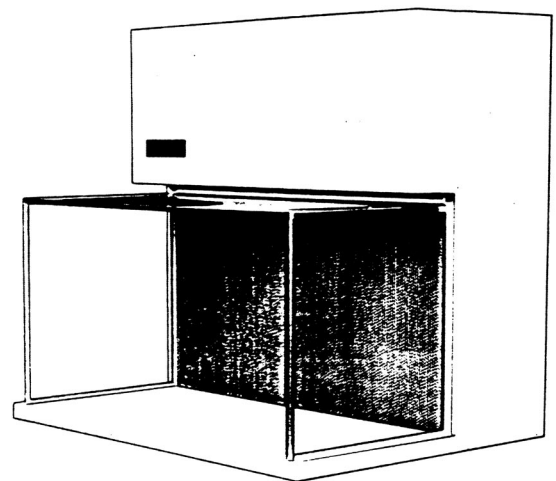

 For more information or to download or fax this product from the web, simply go to:  
[www.cleanairproducts.com/201](http://www.cleanairproducts.com/201)

## Series 201 Horizontal Flow Clean Bench

## Technical Data continued

**Electrical**

120V, single phase, 3-wire electrical system with 8 ft. flex power cord. (Up to 20 amps)

15 amp motor speed infinitely variable with Solid State controller.

15 amp duplex outlet installed in right front of base for auxiliary equipment. Outlet is fused from main cabinet circuit breaker.

Independent motor and light on/off switches.

Direct drive motor and dynamically balanced blower assembly is isolated from cabinet by rubber mounts and by the Flex Duct connection.

**Airflow**

Factory set at 90 FPM: maintained by adjusting blower speed as filter pressure increases over period of use.

**Sound Level**

Less than 60dba with air ambient of 55dba. (75dba – units with twin blowers.)

**Dimensions**

White "Formica" cover over particle board table top: 21-1/2 in. deep.

**Overall Width of Cabinet: Dimension "A"**

- \_\_\_ 2 foot = 26-1/2 in.
- \_\_\_ 3 foot = 38-1/2 in.
- \_\_\_ 4 foot = 50-1/2 in.
- \_\_\_ 5 foot = 62-1/2 in.
- \_\_\_ 6 foot = 74-1/2 in.
- \_\_\_ 8 foot = 98-1/2 in.

**Overall Depth of Cabinet (front to back): 34 in.****Electrical Information and Blower Motor Sizes**

201-*T24	Blower	Motor	Fluorescent Lamp	Electrical	
224	(1) DD-10-4	1/3HP PSC	(2)	120V/10/60HZ	7.9 amp
324	(1) DD-10-4	1/3HP PSC	(2)	120V/10/60HZ	7.9 amp
424	(1) DD-10-6	1/2HP PSC	(2)	120V/10/60HZ	9.4 amp
524	(1) DD-10-8	1/2HP PSC	(2)	120V/10/60HZ	9.4 amp
624	(1) DD-10-8	3/4HP PSC	(2)	120V/10/60HZ	12.4 amp
824	(1) DD-10-6	1/2HP PSC	(2)	120V/10/60HZ	17.4 amp
<b>201-*T30</b>					
230	(1) DD-10-4	1/3HP PSC	(2)	120V/10/60HZ	7.9 amp
330	(1) DD-10-6	1/3HP PSC	(2)	120V/10/60HZ	7.9 amp
430	(1) DD-10-6	1/2HP PSC	(2)	120V/10/60HZ	9.4 amp
530	(1) DD-10-8	1/2HP PSC	(2)	120V/10/60HZ	9.4 amp
630	(2) DD-10-8	3/4HP PSC	(2)	120V/10/60HZ	12.4 amp
830	(2) DD-10-6	1/2HP PSC	(2)	120V/10/60HZ	17.4 amp
<b>201-*T36</b>					
336	(1) DD-10-8	1/2HP PSC	(2)	120V/10/60HZ	9.4 amp
436	(1) DD-10-8	1/2HP PSC	(2)	120V/10/60HZ	9.4 amp
536	(1) DD-10-8	3/4HP PSC	(2)	120V/10/60HZ	12.4 amp
636	(2) DD-10-8	1/2HP PSC	(2)	120V/10/60HZ	17.4 amp
836	(2) DD-10-6	1/2HP PSC	(2)	120V/10/60HZ	17.4 amp
<b>201-*T48</b>					
448	(1) DD-10-8	3/4HP PSC	(2)	120V/10/60HZ	12.4 amp
548	(1) DD-10-8	1/2HP PSC	(2)	120V/10/60HZ	17.4 amp
648	(2) DD-10-8	1/2HP PSC	(2)	120V/10/60HZ	17.4 amp
848	(2) DD-10-6	3/4HP PSC	(2)	120V/10/60HZ	23.4 amp

**Work Area Height: Dimension "B"**

- \_\_\_ 22-1/2 in. (24 Series)
- \_\_\_ 28-1/2 in. (30 Series)
- \_\_\_ 34-1/2 in. (36 Series)
- \_\_\_ 46-1/2 in. (48 Series)

**Work Area Height: Dimension "C"**

- \_\_\_ 2 foot = 22 in.
- \_\_\_ 3 foot = 34 in.
- \_\_\_ 4 foot = 46 in.
- \_\_\_ 5 foot = 58 in.
- \_\_\_ 6 foot = 70 in.
- \_\_\_ 8 foot = 94 in.

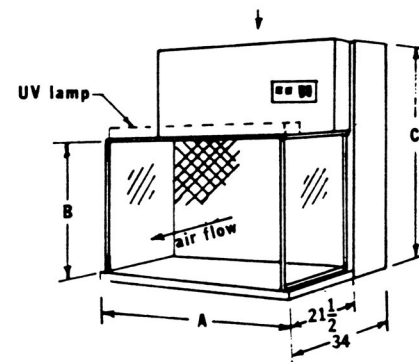

**Overall Height of Cabinet:  
 Dimension "D"**

**201\*24**

- 224 = 39-1/2 in.
- 324 = 39-1/2 in.
- 424 = 40-1/2 in.
- 524 = 40-1/2 in.
- 624 = 43.0 in.
- 824 = 41-1/2 in.

**201\*30**

- 230 = 45-1/2 in.
- 330 = 45-1/2 in.
- 430 = 46-1/2 in.
- 530 = 46-1/2 in.
- 630 = 48-1/2 in.
- 830 = 48-1/2 in.

**201\*36**

- 336 = 52-1/2 in.
- 436 = 56-1/2 in.
- 536 = 56-1/2 in.
- 636 = 57-1/2 in.
- 836 = 57-1/2 in.

**201\*48**

- 448 = 68-1/2 in.
- 548 = 68-1/2 in.
- 648 = 68-1/2 in.
- 848 = 68-1/2 in.

**Optional Accessories**

- \_\_\_ "Minihelic" 0 to 2 inch differential pressure gauge. (HEPA)
- \_\_\_ Stainless steel table top
- \_\_\_ Table top support legs
- \_\_\_ Gas cock
- \_\_\_ Electrical duplex outlet (additional)
- \_\_\_ Bar and hooks for bottle hanging
- \_\_\_ Gold fluorescent lamps
- \_\_\_ Photoresist gold lamp sleeves
- \_\_\_ Ultraviolet germicidal lamps
- \_\_\_ Conductive Formica top

- \_\_\_ CAS251 Console Base 30 inches high or 36 inches high
  - \_\_\_ Anti-static grid and power supply
  - \_\_\_ Painted cabinet – color code, manufacturer and chip required
- Meets requirements of the NEC electrical codes.

Shipped fully assembled ready for operation and certified to meet or exceed Class 100 conditions of Federal Standard 209D.

Operations manual and test reports provided with unit at shipment.

**Estimated Weight**

**201\*24**

- 324 = 270 lb.
- 424 = 300 lb.
- 524 = 350 lb.
- 624 = 400 lb.
- 824 = 580 lb.

**201\*30**

- 330 = 300 lb.
- 430 = 350 lb.
- 530 = 400 lb.
- 630 = 450 lb.
- 830 = 670 lb.

**201\*36**

- 336 = 350 lb.
- 436 = 400 lb.
- 536 = 450 lb.
- 636 = 500 lb.
- 836 = 750 lb.

**201\*48**

- 448 = 470 lb.
- 548 = 550 lb.
- 648 = 650 lb.
- 848 = 800 lb.

Standard units shipped F.O.B. factory padded van.

Equipment specification, dimension and upgrades are subject to change without notice.

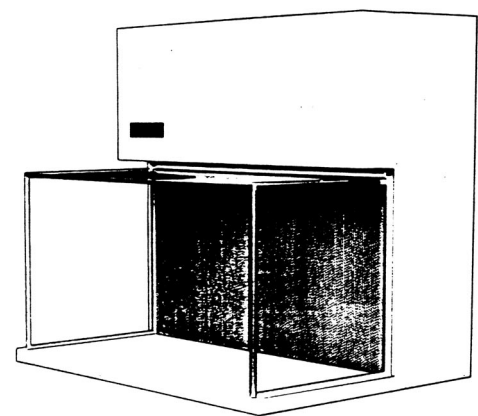

Specifications subject to change. Please contact factory for details.