

ADA-COMPLIANT AIR SHOWERS

CAP701KD-ST-7072, RH-7072 and LH-7072

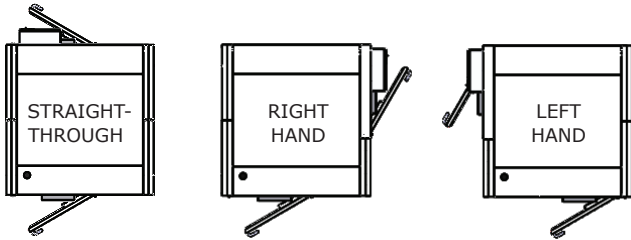

Quality construction

- Durable heavy-gauge painted steel
- High velocity and air volume rate for fast, efficient cleaning
- Inspection panels for high-pressure supply ducts

Easy electronics

- Microprocessor controller, touchscreen controls
- Magnetic interlocks
- LED lighting

Advanced filters and sealants

- Urethane sealant
- Standard-size HEPA filters and prefilters
- Zero-leak, negative-pressure reliability seal on HEPA filter gasket

Optimal configuration

- Easy service access
- Customization options

For a full description see the
CAP air showers brochure.



CAP701KD-RH-7072-WR

CAP701KD-ST-7072 ADA-compliant air showers are larger than standard models to accommodate individuals in wheel chairs and other assistance equipment. Optional automatic doors are available. Refer to local code officials for the requirements for your specific application.

CAP701 ADA-compliant air showers can be custom-designed and ordered in a variety of configurations, including right-hand or left-hand turn designs. Contact the factory for your specific application.

Clean Air Products air showers feature rugged construction and adjustable, high velocity air jets. The 16-gauge painted steel shell (*stainless steel* optional) with heavy-duty glass door and door closer withstand the rigors of shipping, installation and daily use. Steel construction reduces the chances of biological growth and contamination.

A powerful 3-phase 5 HP blower motor provides approximately 1900 CFM at 7800 LFM. This high air-flow volume (power) combined with the high nozzle velocity (force) quickly and efficiently clean personnel inside the air shower.

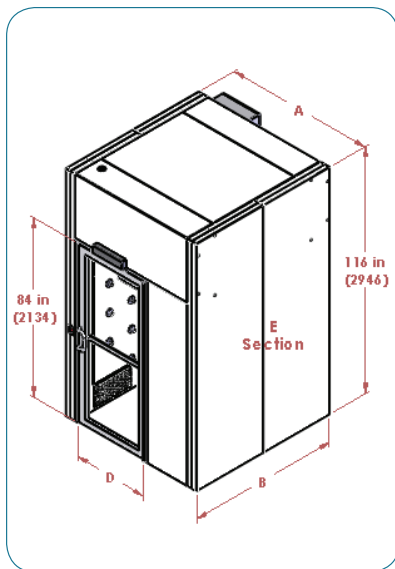
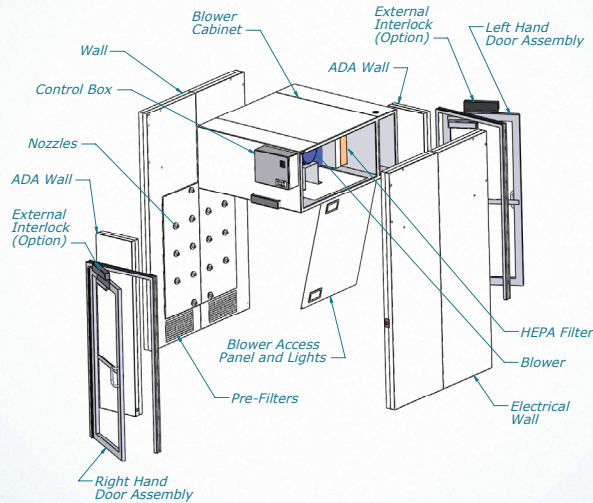

PRODUCT DIMENSIONS: inches (mm) (Common sizes – additional sizing available)					
Model Number	A Outside width	B Outside depth	D Door width	Qty of E 54 in. sections	Qty of E 72 in. sections
CAP701KD-ST-7072	70.75 (1797)	72 (1829)	36 (914)	0	1
CAP701KD-RH-7072	70.75 (1797)	72 (1829)	36 (914)	0	1
CAP701KD-LH-7072	70.75 (1797)	72 (1829)	36 (914)	0	1

42" DOORS AVAILABLE UPON REQUEST

LEARN MORE

Clean Air Products designs the CAP701 Series air showers for optimal performance, customization, configuration and maintenance. For more information on CAP701 Series air showers including CAD drawings, RFQs, purchase specifications, exploded views and options, visit:

www.cleanairproducts.com/product-category/air-showers



www.cleanairproducts.com

8605 Wyoming Ave. N. • Minneapolis, Minnesota 55445

763.425.9122 • 800.423.9728 • fax: 763.425.2004

e-mail: sales@cleanairproducts.com