

MULTI-UNIT TUNNEL AIR SHOWERS

CAP701KD-ST2, ST3, ST4 and ST5

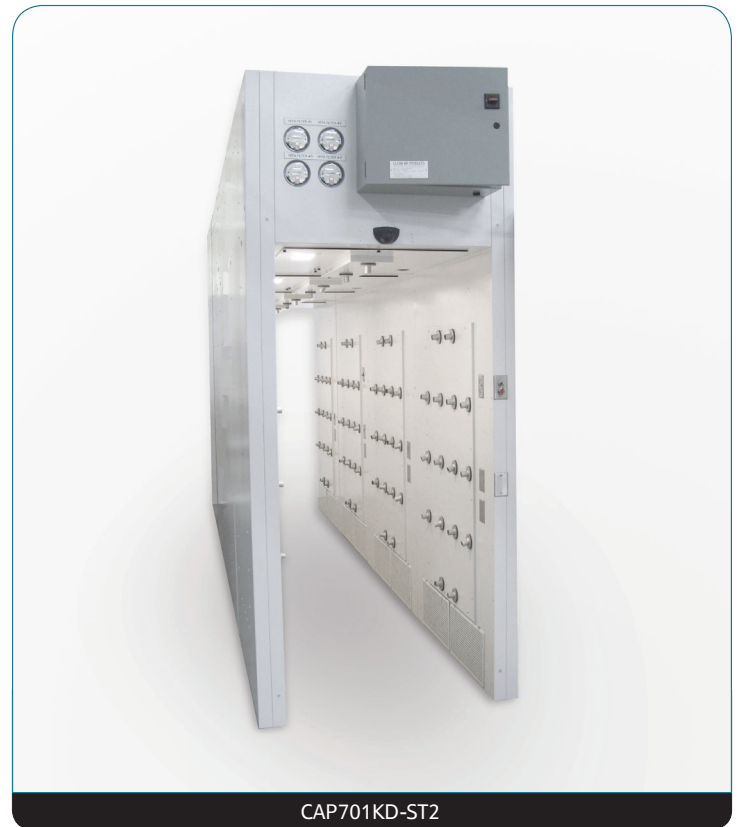
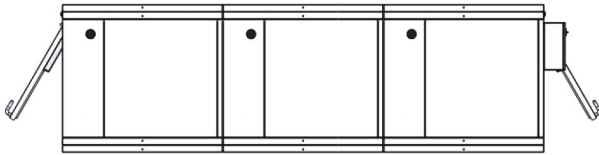

Quality construction

- Durable heavy-gauge painted steel
- High velocity and air volume rate for fast, efficient cleaning
- Inspection panels for high-pressure supply ducts

Easy electronics

- Microprocessor controller, touchscreen controls
- Magnetic interlocks
- LED lighting

Advanced filters and sealants

- Urethane sealant
- Standard-size HEPA filters and prefilters
- Zero-leak, negative-pressure reliability seal on HEPA filter gasket

Optimal configuration

- Easy service access
- Customization options

For a full description see the
CAP air showers brochure.

CAP701KD “tunnel” air showers are created by combining two or more single units (and 90-degree units) to form a longer unit. Tunnels are used for “batch” cleaning—several people entering and exiting as a group—or for “continuous flow” cleaning—one person walking the length of the tunnel.

Low-profile, ADA-compliant and additional configurations are available. Contact the factory for your specific requirement.

Clean Air Products air showers feature rugged construction and adjustable, high velocity air jets. The 16-gauge painted steel shell (*stainless steel* optional) with heavy-duty glass door and door closer withstand the rigors of shipping, installation and daily use. Steel construction reduces the chances of biological growth and contamination.

A powerful 3-phase 5 HP blower motor provides approximately 1900 CFM per section at 7800 LFM. This high air-flow volume (power) combined with the high nozzle velocity (force) quickly and efficiently clean personnel inside the air shower.

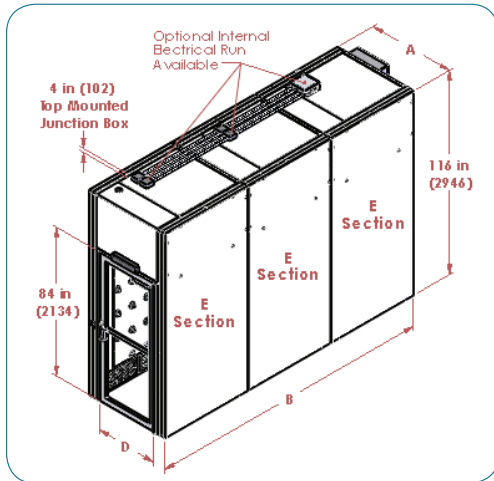
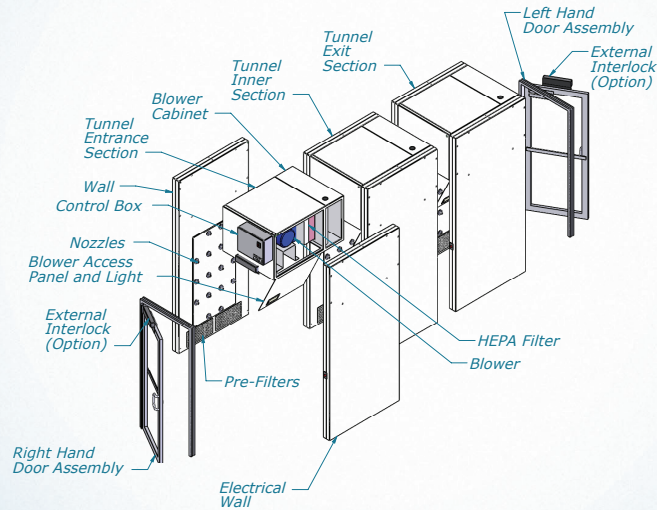

PRODUCT DIMENSIONS: inches (mm) (Common sizes for multi-unit tunnels – additional sizing available)				
Model Number	A Outside width	B Outside depth	D Door width	Qty of E 54 in. sections
CAP701KD-ST2-49108	49.75 (1264)	108 (2744)	36 (914)	2
CAP701KD-ST3-49162	49.75 (1264)	162 (4115)	36 (914)	3
CAP701KD-ST4-49216	49.75 (1264)	216 (5487)	36 (914)	4
CAP701KD-ST5-49270	49.75 (1264)	270 (6858)	36 (914)	5

The best performance uses the CAP701KD-ST-4954 sections. Wider and longer sections available upon request. Alternate 90-degree sections can be installed on the ends or in the middle of the air shower.

LEARN MORE

Clean Air Products designs the CAP701 Series air showers for optimal performance, customization, configuration and maintenance. For more information on CAP701 Series air showers including CAD drawings, RFQs, purchase specifications, exploded views and options, visit:

www.cleanairproducts.com/product-category/air-showers



www.cleanairproducts.com

8605 Wyoming Ave. N. • Minneapolis, Minnesota 55445
763.425.9122 • 800.423.9728 • fax: 763.425.2004
e-mail: sales@cleanairproducts.com